

METAL DOOR

SERIES	FUNCTIONS	FEATURE ① (SOLENOID)	FEATURE ② (CYLINDER)	FEATURE ③ (54-PREFIX)	RACEWAY LOCATION
8300, 8900, 9900	775, 776	X	OUTSIDE ONLY	--	Ⓐ
	54-775, 54-776	X	OUTSIDE ONLY	X	Ⓐ
	ALL OTHER 54-700	--	SEE NOTE 2	X	Ⓑ
9800**	775, 776	X	THRU DOOR	--	Ⓐ
	54-775, 54-776	X	THRU DOOR	X	Ⓐ
	ALL OTHER 54-700	--	SEE NOTE 2	X	Ⓑ
8300, 8900, 9900 9800** 8700, 9700	773, 774	X	--	--	Ⓐ
	54-773, 54-774	X	--	X	Ⓐ
	ALL OTHER 54-700	--	SEE NOTE 2	X	Ⓑ

** 12-9800 NOT AVAILABLE W/ SOLENOID ET TRIM

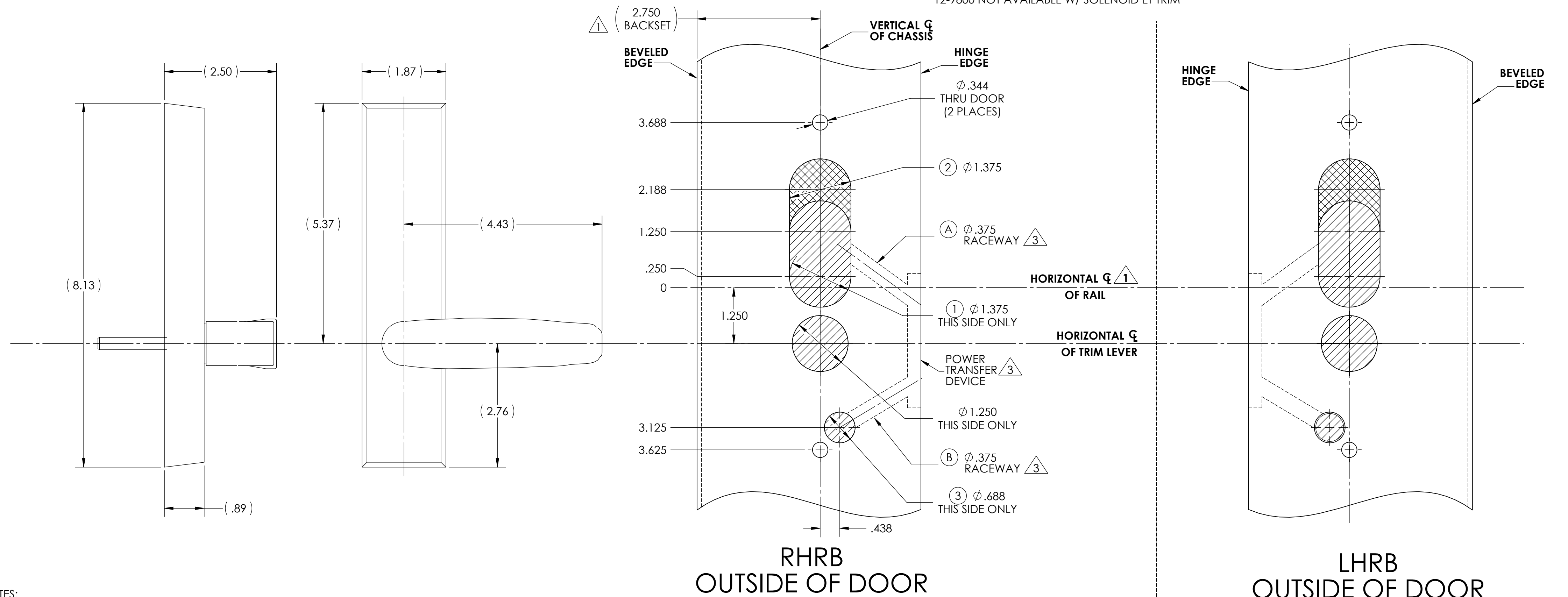

NOTES:

- FOR LOCATION OF VERTICAL CENTERLINES, HORIZONTAL CENTERLINES AND ALL ADDITIONAL EXIT DEVICES PREP. REFER TO APPROPRIATE EXIT DEVICE TEMPLATE.
- FOR ADDITIONAL "ET" DOOR PREP CUTOUTS REFER TO TEMPLATE 4277.
- a. $\phi .375$ RACE WAY FOR ELECTRO LYNX APPLICATIONS REFER TO MCKINNEY TRANSFER CATALOG.
b. DOOR MANUFACTURER TO MAKE PROVISIONS TO PROTECT WIRES FROM ABRASION.
c. DOOR MANUFACTURER TO PROVIDE CLEARANCE REINFORCEMENT TO ALLOW INSERTION OF ELECTRICAL HINGE.
d. CONSULT WITH POWER TRANSFER MANUFACTURER FOR DEVICE CUTOUT.
- SUITABLE REINFORCEMENT REQUIRED FOR METAL DOORS.
- BEVEL REQUIRED (NOT SHOWN), PREP TO ANSI A115 SPECIFICATIONS.
- TOLERANCE ALL DIMENSIONS $\pm .015$.
- FOR WOOD DOOR APPLICATIONS SEE SHEET 2 (8300, 8900, 9900) OR SHEET 3 (8700, 9700, 9800)

WOOD DOOR (8300, 8900, 9900)

SERIES	FUNCTIONS	FEATURE ① (SOLENOID)	FEATURE ② (CYLINDER)
8300, 8900, 9900	775, 776	X	X
	773, 774	X	--

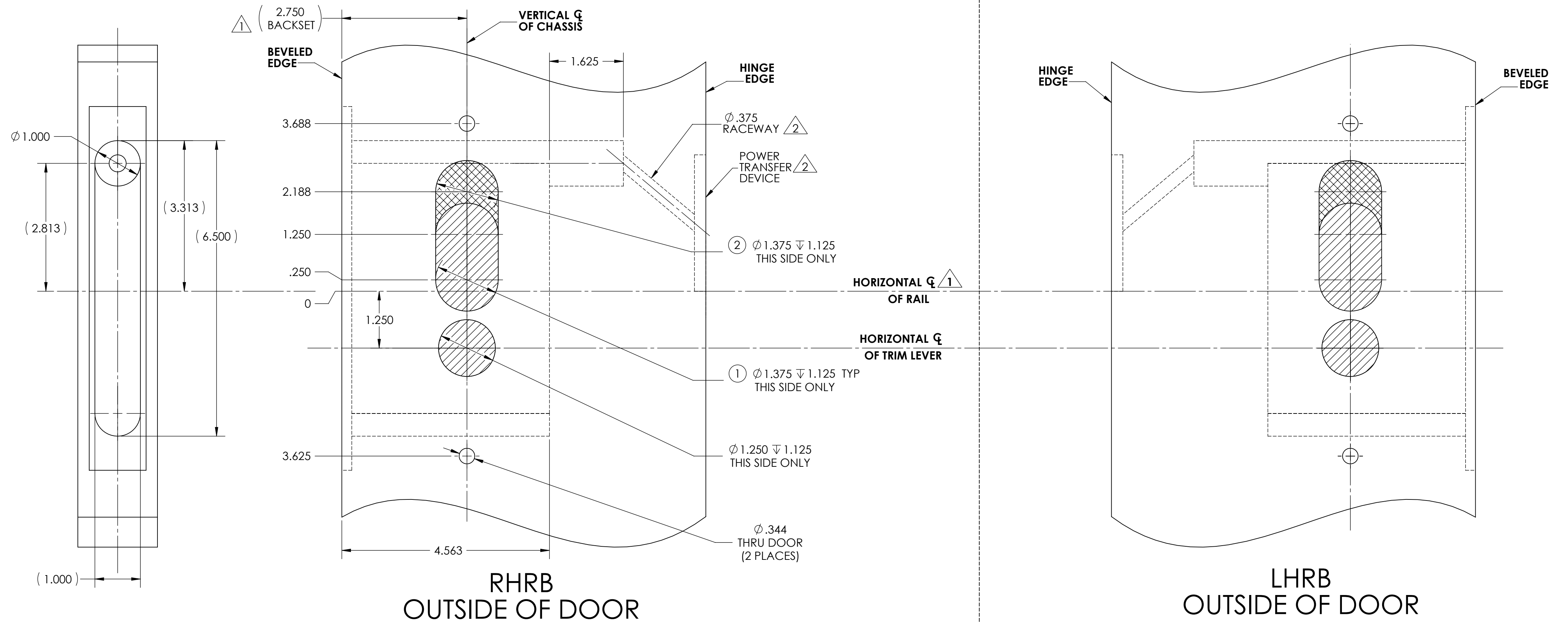

- NOTES:
- FOR LOCATION OF VERTICAL CENTERLINES, HORIZONTAL CENTERLINES AND ALL ADDITIONAL EXIT DEVICES PREP. REFER TO APPROPRIATE EXIT DEVICE TEMPLATE.
 - ϕ .375 RACE WAY FOR ELECTRO LYNX APPLICATIONS REFER TO MCKINNEY TRANSFER CATALOG.
 - DOOR MANUFACTURE TO MAKE PROVISIONS TO PROTECT WIRES FROM ABRASION.
 - DOOR MANUFACTURE TO PROVIDE CLEARANCE REINFORCEMENT TO ALLOW INSERTION OF ELECTRICAL HINGE.
 - CONSULT WITH POWER TRANSFER MANUFACTURER FOR DEVICE CUTOUT.
 - BEVEL REQUIRED (NOT SHOWN), PREP TO ANSI A115 SPECIFICATIONS.
 - TOLERANCE ALL DIMENSIONS $\pm .015$.
 - FOR TRIM DIMENSIONS OR METAL DOOR PREP SEE SHEET 1.
 - FOR WOOD DOOR (8700, 9700, 9800) PREP SEE SHEET 3.

WOOD DOOR (8700, 9700, 9800)

SERIES	FUNCTIONS	FEATURE ① (SOLENOID)	FEATURE ② (CYLINDER)
9800**	775, 776	X	X
8700, 9700, 9800**	773, 774	X	--

** 12-9800 NOT AVAILABLE W/ SOLENOID ET TRIM

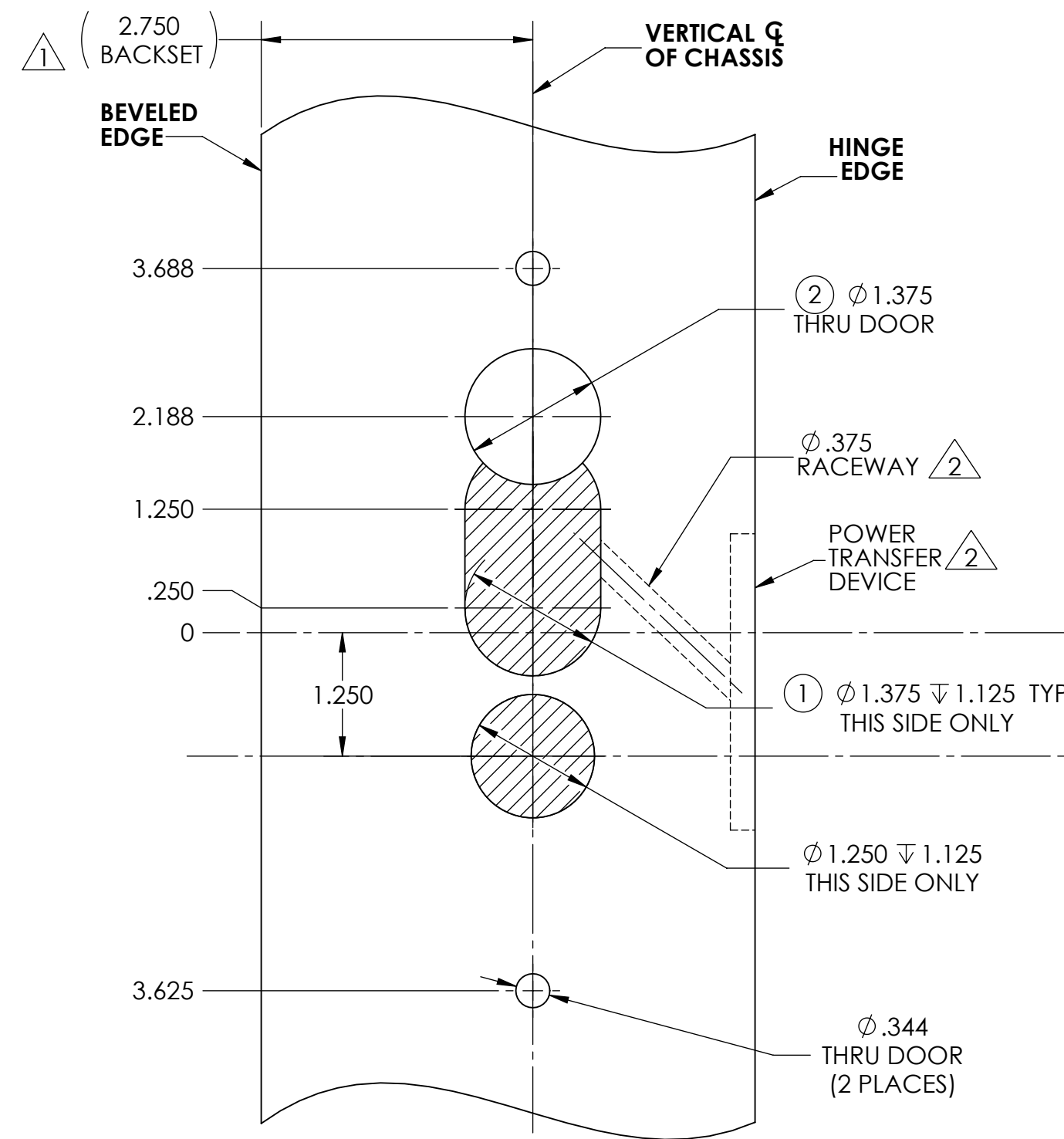

RHRB
OUTSIDE OF DOOR

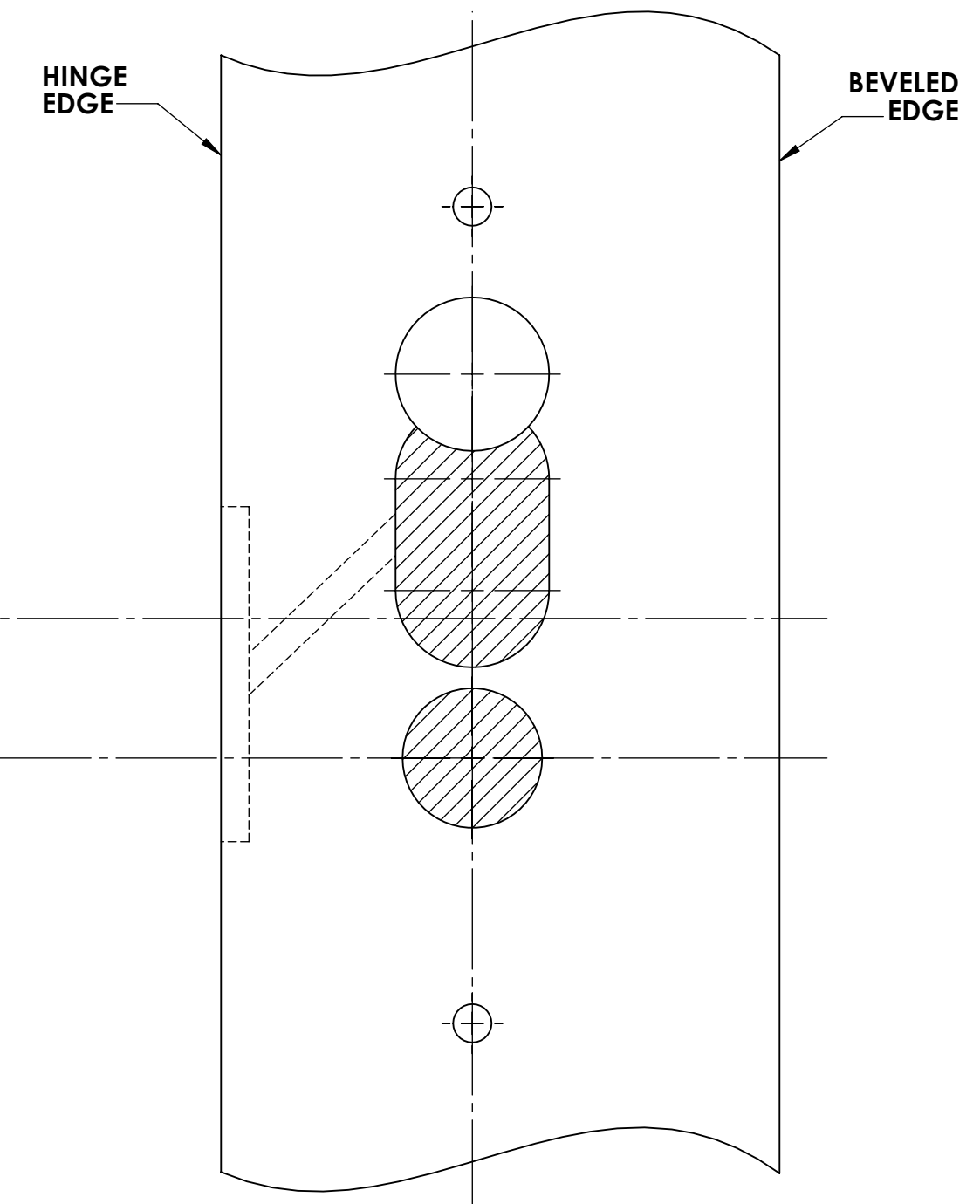

LHRB
OUTSIDE OF DOOR

- NOTES:
- FOR LOCATION OF VERTICAL CENTERLINES, HORIZONTAL CENTERLINES AND ALL ADDITIONAL EXIT DEVICES PREP. REFER TO APPROPRIATE EXIT DEVICE TEMPLATE.
 - $\phi .375$ RACE WAY FOR ELECTRO LYNX APPLICATIONS REFER TO MCKINNEY TRANSFER CATALOG.
 - DOOR MANUFACTURER TO MAKE PROVISIONS TO PROTECT WIRES FROM ABRASION.
 - DOOR MANUFACTURE TO PROVIDE CLEARANCE REINFORCEMENT TO ALLOW INSERTION OF ELECTRICAL HINGE.
 - CONSULT WITH POWER TRANSFER MANUFACTURER FOR DEVICE CUTOUT.
 - BEVEL REQUIRED (NOT SHOWN), PREP TO ANSI A115 SPECIFICATIONS.
 - TOLERANCE ALL DIMENSIONS $\pm .015$.
 - FOR TRIM DIMENSIONS OR METAL DOOR PREP SEE SHEET 1.
 - FOR WOOD DOOR (8300, 8900, 9900) PREP SEE SHEET 2.