

Instructions for Trim Installation

For assistance, contact SARGENT at 800-810-WIRE (9473) or www.sargentlock.com

SARGENT

ASSA ABLOY

Copyright © SARGENT Manufacturing. All rights reserved.
Reproduction in whole or in part without the express written permission of SARGENT Manufacturing is prohibited.

FOR 28- D-LL(LP,LB) – DUMMY PULL

28-K-LL(LP,LB) – KEY RETRACTS LATCH BOLT

28-N-LL(LP,LB) – LEVER OPERATES ONLY WHEN KEY IS INSERTED AND TURNED

28-C-LL(LP,LB) – CYLINDER LOCK & UNLOCKS LEVER

28-L-LL(LP,LB) – PASSAGE - LEVER ALWAYS OPERATIVE

NOTE: THE TRIM IS FACTORY ASSEMBLED FOR RIM AND VERTICAL ROD SERIES EXIT DEVICES

1. REMOVE TWO SCREWS

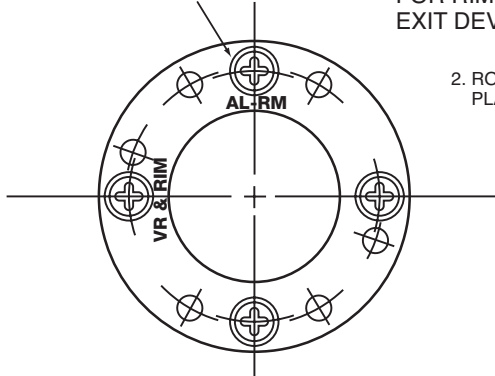

POSITION FOR 5100 - 5800 & 12-5800 EXIT ALARMS

2. ROTATE MOUNTING PLATE 90° CLOCKWISE

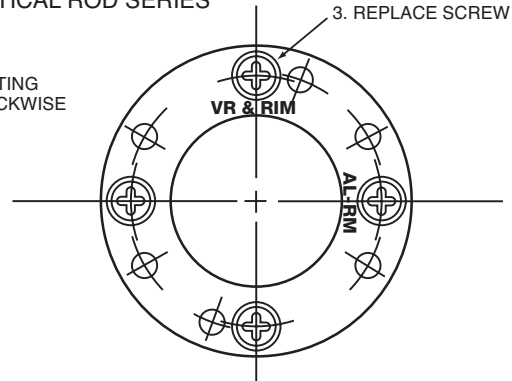

POSITION FOR RIM AND VERTICAL ROD SERIES EXIT DEVICES

STEP 1. DISASSEMBLY OF TRIM BEFORE INSTALLING

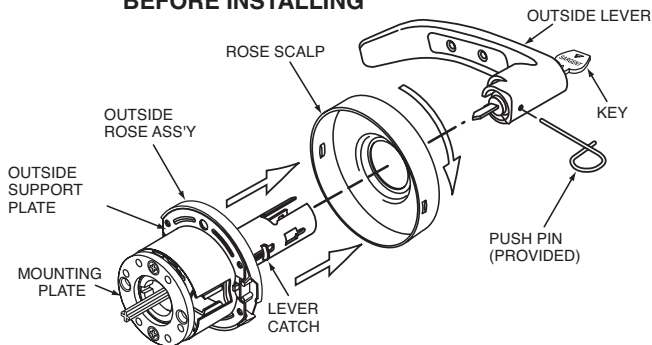

REMOVE LEVER AND ROSE SCALP

1. TURN KEY COUNTER CLOCKWISE AS FAR AS IT WILL GO. (FOR 04, 06, & 13 FUNCTION)
2. TURN KEY 45° CLOCKWISE.
3. DEPRESS LEVER CATCH THROUGH HOLE IN LEVER. (FOR ALL FUNCTION)
4. SLIDE LEVER FROM THE TUBE.
5. REMOVE ROSE SCALP.

STEP 2.

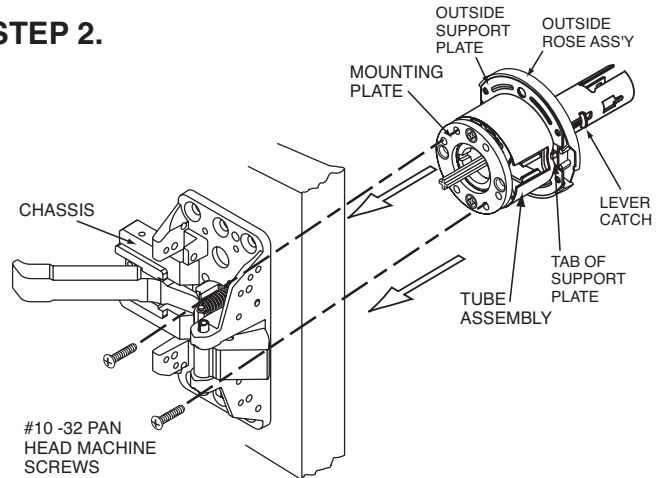

INSTALLING TRIM

INSERT UNIT IN 2-1/8" HOLE (LEVER CATCH HAS TO FACE EDGE OF DOOR). BE SURE THE TWO TABS OF SUPPORT PLATE ENGAGE TWO NOTCHES IN 2-1/8" HOLE. THRU BOLT CHASSIS TO TUBE ASSEMBLY WITH (2) #10-32 SCREWS. DO NOT TIGHTEN SCREWS AT THIS TIME.

STEP 3.

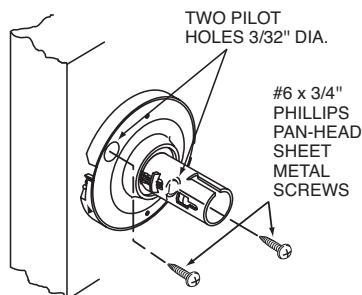

SECURE TRIM TO DOOR

1. DRILL TWO PILOT HOLES 3/32" DIA. THROUGH SUPPORT PLATE AT LOCATION SHOWN.
2. SECURE TRIM TO DOOR WITH TWO #6 x 3/4" SCREWS PROVIDED.

STEP 4.

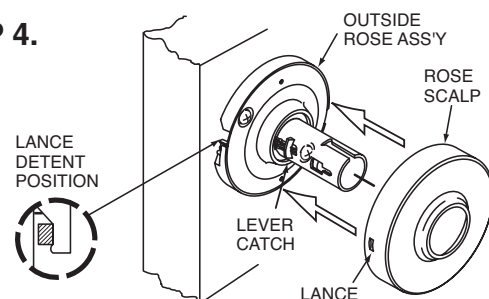

ROSE SCALP INSTALLATION

1. SLIGHTLY LOOSEN THE TWO #10-32" SCREWS FROM INSIDE. TWIST THE SCALP IN PLACE AS SHOWN.
2. TIGHTEN THE TWO #10-32 SCREWS SECURELY AT THIS TIME.

CONT'D FROM FRONT PAGE

STEP 5.

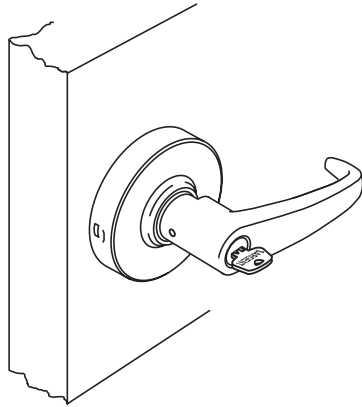

INSTALL LEVER

1. INSERT FLAT SCREWDRIVER INTO SLOT OF KEY CAM AND TURN ALL THE WAY COUNTER CLOCKWISE.
2. WITH KEY PARTIALLY REMOVED FROM CYLINDER, PUSH LEVER ON TUBE AS FAR AS IT WILL GO.
3. COMPLETELY INSERT KEY AND TURN 45° COUNTERCLOCKWISE. PUSH LEVER AGAIN UNTIL LEVER CATCH IS ENGAGED, SECURING THE LEVER, PULL ON IT TO BE SURE LEVER CATCH IS IN PLACE.
4. CHECK FOR PROPER OPERATION: TURN KEY FULLY CLOCKWISE OR COUNTER CLOCKWISE. KEY WILL REMOVE IN A HORIZONTAL POSITION WITH BITTING (NOTCHES) TOWARD HINGE SIDE OF DOOR.

28-D-LL(LP, LB) – DUMMY PULL

INSTALLING TRIM

INSERT UNIT IN 2-1/8" HOLE (LEVER CATCH HAS TO FACE EDGE OF DOOR). BE SURE THE TWO TABS OF SUPPORT PLATE ENGAGE TWO NOTCHES IN 2-1/8" HOLE. SNUG UP SCREWS AT THIS TIME, NOT TIGHT TO CHASSIS WITH TWO #10-32 SCREWS AS SHOWN.

MOVE 2 SCREWS TO LEFT SIDE OF DOOR.

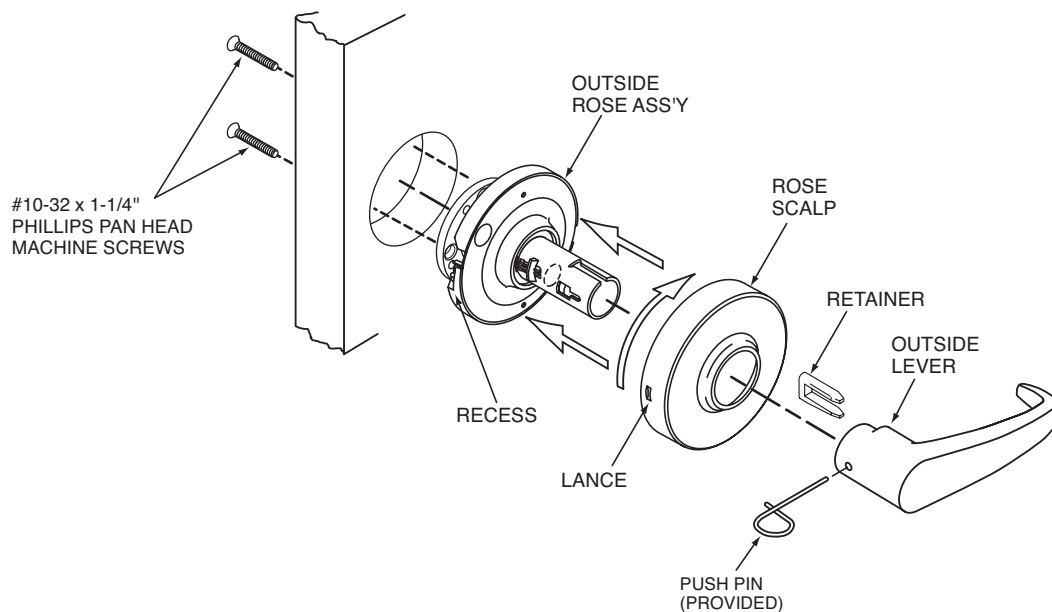

SARGENT®

ASSA ABLOY