

7100(F), 7150(F)(WS) Rim and SquareBolt® Single Doors or Pairs with Mullion

ACCENTRA ASSA ABLOY

Installation Instructions

NOTE: These installation instructions cover standard product only. To install options, such as shim kits or interlock brackets, refer to the instructions packed with the optional component.

Packed For Reinforced Metal Doors.

Optional Sex Nuts Required For Unreinforced Metal, Composite and Wood Doors.

Outside Trim: Device is packed ready for any applicable ASSA ABLOY ACCENTRA™ Trim.

7100, 7150: Panic Label

7100F, 7150F: Fire Label

7150(F)WS: Windstorm Label

ABBREVIATION	FASTENER DESCRIPTION
PPHFTCS	PHILLIPS PAN HEAD TYPE F THREAD CUTTING SCREW
PFHMS	PHILLIPS ROUND HEAD MACHINE SCREW
PFMHS	PHILLIPS FLAT HEAD MACHINE SCREW
PFHUMS	PHILLIPS FLAT HEAD UNDER CUT MACHINE SCREW

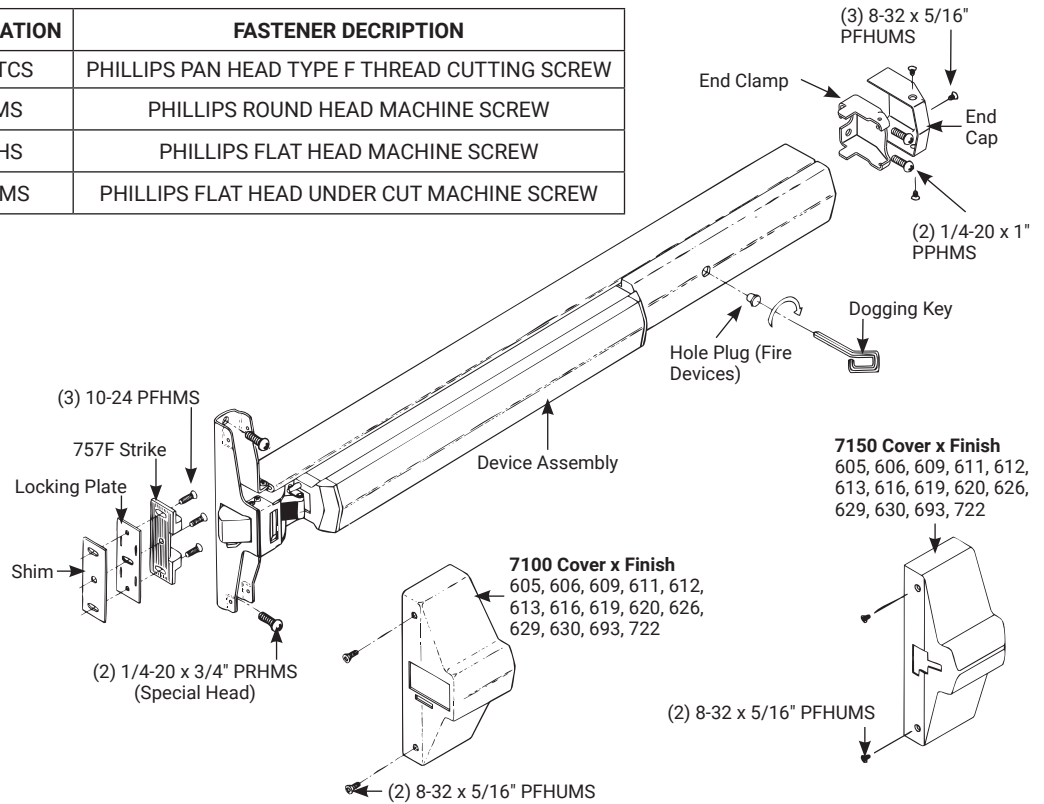

Dogging

Feature to hold bolts retracted and touchpad depressed, for push-pull door operation.

To Dog Device

1. Insert dogging key.
2. Hold touchbar depressed.
3. Turn key 1/4 turn clockwise.

(Not a feature of fire labeled devices.)

Fire Rated Application

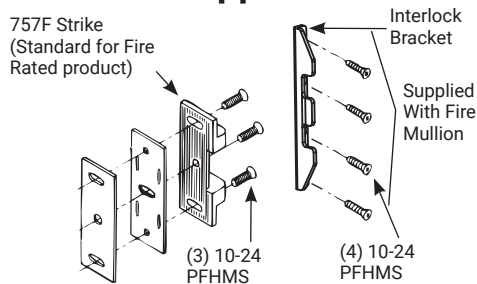

Windstorm Application

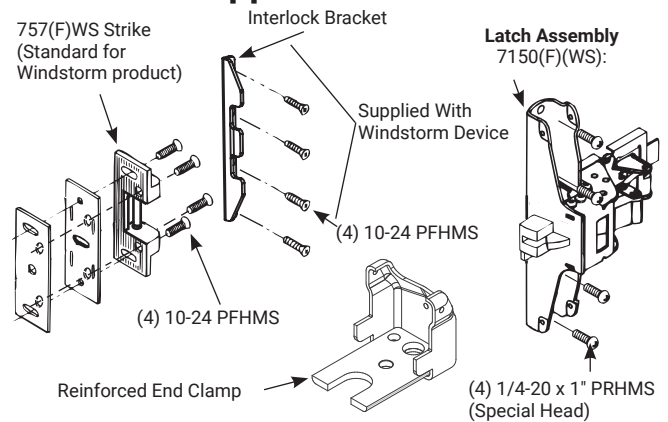

⚠ WARNING

This product can expose you to lead which is known to the state of California to cause cancer and birth defects or other reproductive harm. For more information go to www.P65warnings.ca.gov.

⚠ WARNING

Attention Installer: Any retrofit or other field modification to a fire rated opening can potentially impact the fire rating of the opening, and ASSA ABLOY makes no representations or warranties concerning what such impact may be in any specific situation. When retrofitting any portion of an existing fire-rated opening, or specifying and installing a new fire-rated opening, please consult with a code specialist or local code official (Authority Having Jurisdiction) to ensure compliance with all applicable codes and ratings.

1-855-557-5078 Ext. 2 • www.accentra-assaabloy.com

80-9470-0000-000 04/24

Experience a safer
and more open world

For Doors of Either Hand

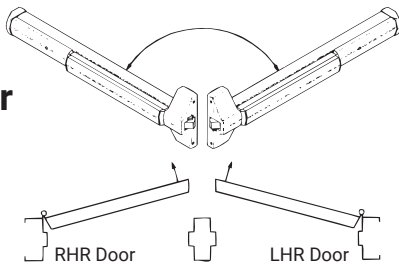

Maintenance

1. Periodically remove covers and coat mechanisms with a silicone base lubricant. This is particularly required in corrosive environments for proper product function.
2. Check mounting fasteners periodically. Retighten if found loose. Apply screw locking compound (available at automotive part stores) or change part fasteners if screws continue to back up.
3. Periodic checks (and adjustments) of strikes are required to compensate for changes in the opening (e.g. door sagging).

Check Before Starting

Unreinforced Doors or Frames

Doors and Frames with walls having a structural thickness (metal skin plus reinforcement or solid hardwood) to engage less than (3) full screw threads are considered unreinforced.

Unreinforced Doors: Use SNB (sex nuts and bolts).

Unreinforced Frames: Use Blind Rivet Nuts.

Recommended fasteners for unreinforced openings are not necessarily supplied by ACCENTRA Security, Inc.

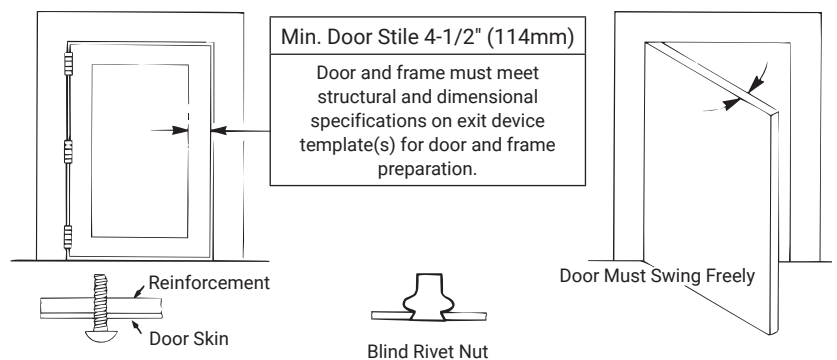

1. Mark Door

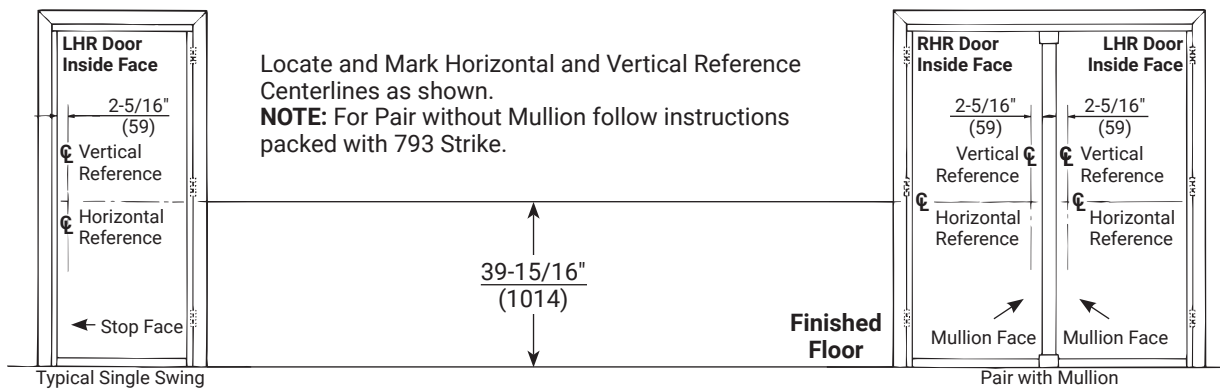

Locate and Mark Horizontal and Vertical Reference Centerlines as shown.
NOTE: For Pair without Mullion follow instructions packed with 793 Strike.

2. Prepare Door and Frame

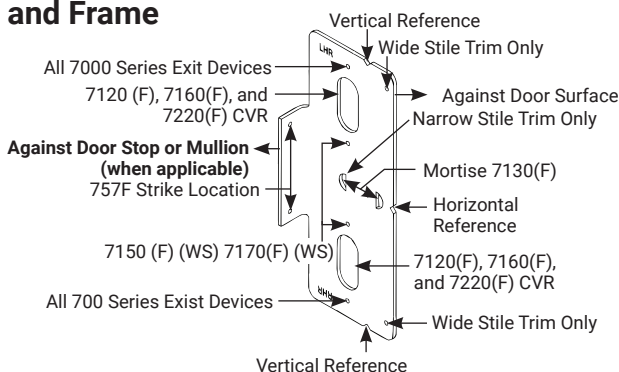

- A. Seat plastic template on door and stop faces.
- B. Align horizontal and vertical centerlines.
- C. Locate and tape Trim Template on door.
(See instructions packed with Trim).

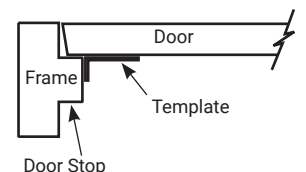

- D. Spot and prepare holes.
Device: Each (2) 1/4-20 Machine Screws* OR (2) 3/8" (10) Dia. Optional Sex Nuts & Bolts. (*) Metal reinforced door only.
Strike: (2) 10-24 Machine Screws OR (2) #10 Wood Screws

80-9470-0000-000 04/24

Experience a safer
and more open world

1-855-557-5078 Ext. 2 • www.accentra-assaabloy.com

Copyright © 1997, 2013, 2023, 2024, ASSA ABLOY ACCENTRA™ Access and Egress Hardware Group, Inc. All rights reserved. Reproduction in whole or in part without the express written permission of ASSA ABLOY Access and Egress Hardware Group, Inc. is prohibited.

7100(F), 7150(F)(WS) Rim and SquareBolt®

Single Doors or Pairs with Mullion Installation Instructions

ACCENTRA

ASSA ABLOY

3. Size Device

Device must be field cut to size, unless standard opening and device are 36" (0.91m).

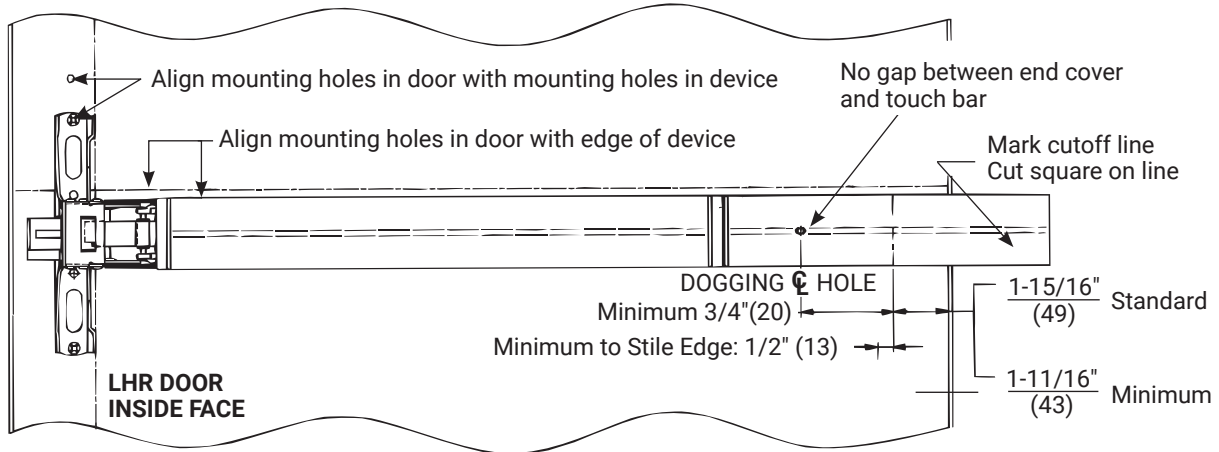

4. Clear Raised Door Molding

Device (head bar and end cap) must seat flush on door surface or on shims that keep it parallel to door face.

(1) Shim Kit #723 needed to clear each 1/8" (3mm) of raised molding. Longer mounting screws needed when more than two (2) Shim Kits are used. See instructions provided with shim kits for installation.

5. Mount Components

- Mount Trim (Follow instructions packed with trim).
- Seat Bar in place. Fasten Device Head (2 PRHMS or SNB).
- Set Bar level. Locate End Clamp holes.
- Prepare End Clamp Mounting holes. Mount End Clamp. (2 #1/4-20 PRHMS or 3/8" (10) dia. SNB)
- Check Bolt Retraction.
 - Depress bar (bolts must retract). Release bar (bolts must extend).
 - Actuate trim (bolts must retract). Release trim actuator (bolts must extend).
 - Depress touchbar, turn dogging key clockwise (bar must remain depressed, bolts must remain retracted). Turn dogging key counterclockwise (bar and bolts must return to extended position).
- Tighten all mounting screws.

NOTE: When resulting operation is faulty, check first for visible binding or interference. If there is no apparent reason for the fault, remove item from the door and recheck its operation before assuming that it is defective.

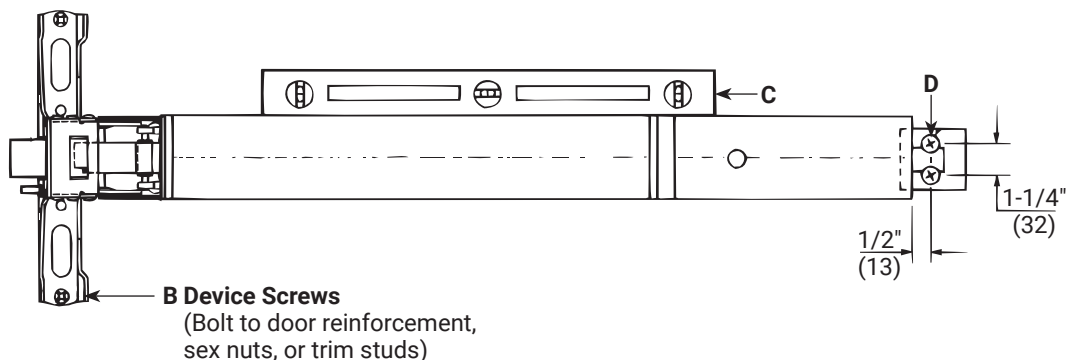

80-9470-0000-000 04/24

1-855-557-5078 Ext. 2 • www.accentra-assaabloy.com

Copyright © 1997, 2013, 2023, 2024, ASSA ABLOY ACCENTRA™ Access and Egress Hardware Group, Inc. All rights reserved. Reproduction in whole or in part without the express written permission of ASSA ABLOY Access and Egress Hardware Group, Inc. is prohibited.

Experience a safer
and more open world

6. Install Strike

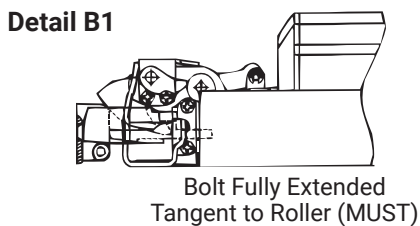
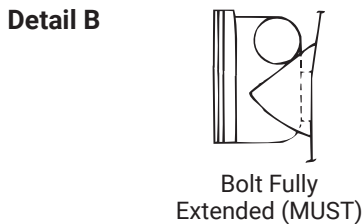
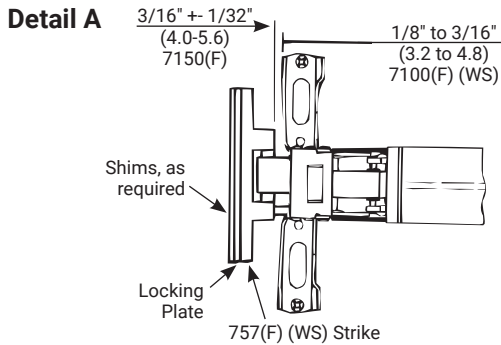

- A. Position Strike Projection (Strike + Locking Plate + Shims, if needed). See **Detail A**.
- B. Position Strike Depth
 - 7100(F) (WS), See **Detail B**.
 - 7150(F) (WS), see **Detail B1**
- C. Fasten Strike Securely, as shown on **Detail C**.
- D. Check Bolt Engagement.
 1. Bolt should retract to clear the strike, when actuated by bar, trim, or dogging action. Bolt should consistently reengage the strike, when actuators are released and the door shuts.
 2. Door should remain latched and not rattle when pushed, pulled, or shaken in/out.
- E. (Fire Devices only) Lock strike in place. See **Detail E**.
 1. Prepare for and install strike center screw (1 #10-24 PFHMS). See **E**.
 2. Windstorm Strike Application: Prepare for and install strike locking screws (2 #10-24 PFHMS). See **E1**.
- F. (Fire Mullion & Windstorm Installations Only) Stabilize strike. See **Detail F**.
 1. Position strike interlock bracket in place as shown. Locate bracket holes.
 2. Prepare interlock bracket mounting holes. Mount interlock bracket (4 #10-24 PFHMS or SNB).

NOTE: Interlock bracket and screws supplied with Fire Mullion and Windstorm products. Windstorm interlock bracket supercedes interlock bracket supplied with Fire Mullion. If using Windstorm product, remove and discard Fire Mullion interlock bracket.

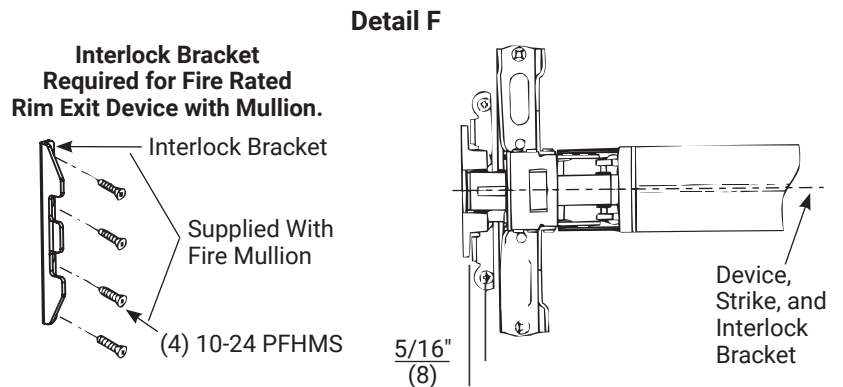
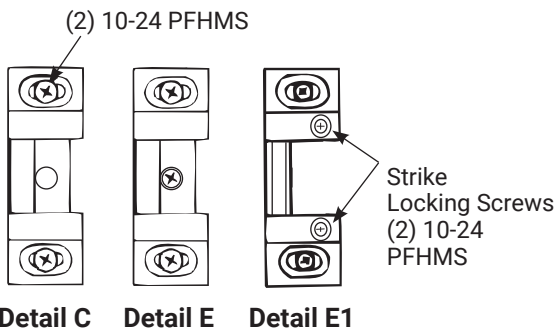

7. Install Head Cover and End Cap Top

