

# 2100(F), 2150(F) & 1800(F)

## SquareBolt® and Rim Exit Devices

### Installation Instructions

# ACCENTRA

# ASSA ABLOY

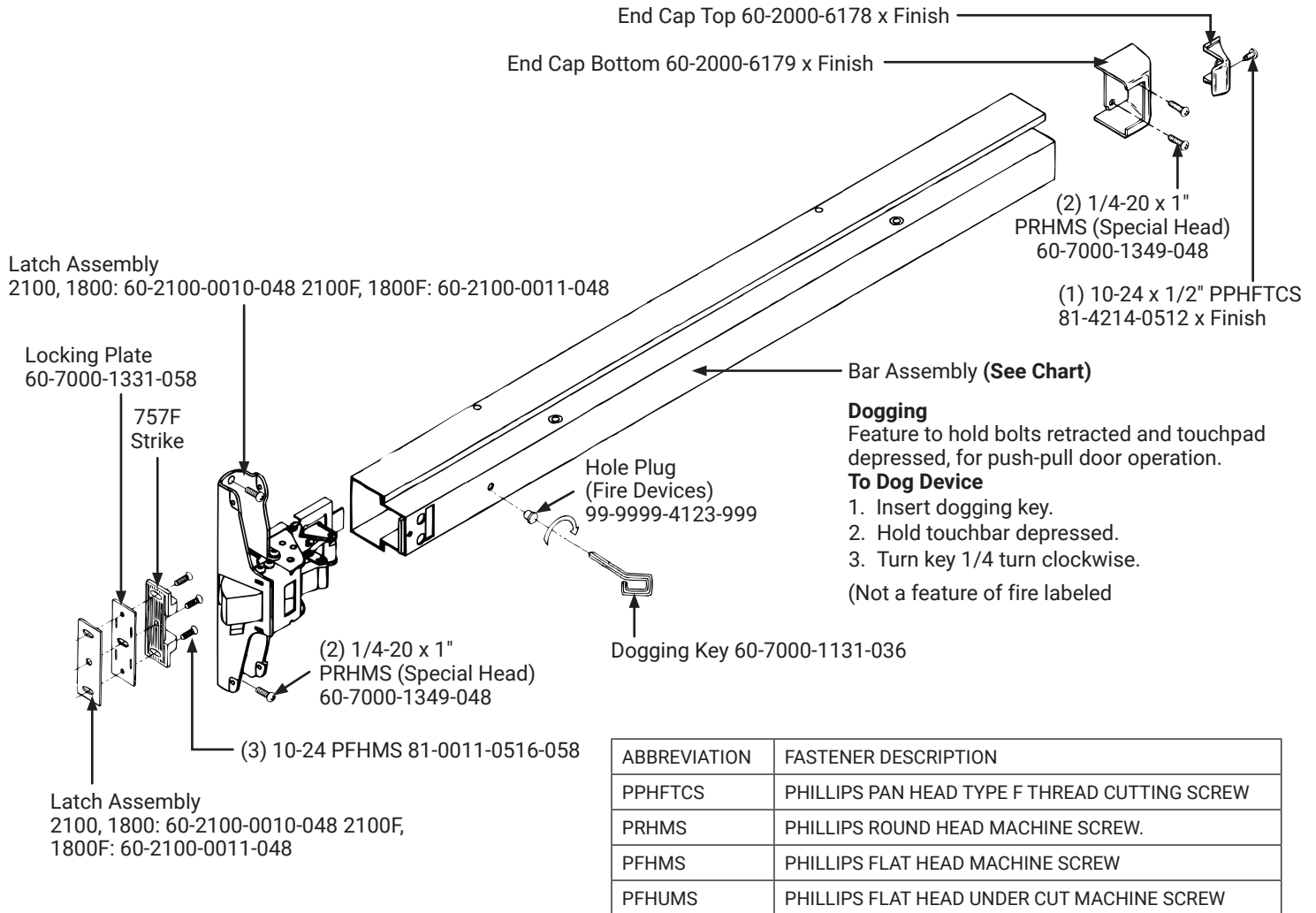

Packed for reinforced metal doors. Optional sex nuts required for unreinforced metal and composite wood doors and are furnished standard with all fire-rated (F) devices. Outside Trim: Device is packed ready for any applicable ASSA ABLOY ACCENTRA™ Trim.

**Note:** These installation instructions cover standard product only. To install options, such as shim kits or interlock brackets, refer to the instructions packed with the optional component. All dimensions are in inches (mm) unless otherwise noted.

**2100, 2150, 1800 (Panic Label)**  
**2100F, 2150F, 1800F (Fire Label)**

### ⚠ WARNING

This product can expose you to lead which is known to the state of California to cause cancer and birth defects or other reproductive harm. For more information go to [www.P65warnings.ca.gov](http://www.P65warnings.ca.gov).

### ⚠ WARNING

Attention Installer: Any retrofit or other field modification to a fire rated opening can potentially impact the fire rating of the opening, and ASSA ABLOY makes no representations or warranties concerning what such impact may be in any specific situation. When retrofitting any portion of an existing fire-rated opening, or specifying and installing a new fire-rated opening, please consult with a code specialist or local code official (Authority Having Jurisdiction) to ensure compliance with all applicable codes and ratings.

80-9421-0000-000 04/24

1-855-557-5078 Ext. 2 • [www.accentra-assaabloy.com](http://www.accentra-assaabloy.com)

Copyright © 2004, 2012, 2023, 2024, ASSA ABLOY ACCENTRA™ Access and Egress Hardware Group, Inc. All rights reserved. Reproduction in whole or in part without the express written permission of ASSA ABLOY Access and Egress Hardware Group, Inc. is prohibited.

Experience a safer  
and more open world

**Latch Assembly**  
2150(F):  
60-2150-0010-048

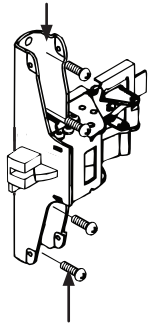

(4) 1/4-20 x 1" PRHMS  
(Special Head)  
60-7000-1349-048

**Cover Used with 2150(F) SquareBolt®**  
Narrow (std): 60-2150-1234 x Finish  
Wide (opt): 60-2150-1244 Finish

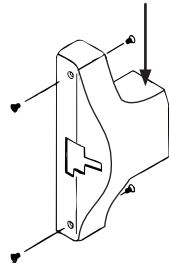

(4) 8-32 x 5/16" PFHMS  
81-0072-0406 x Finish

**Narrow Cover**  
Used With 2100(F)  
60-2000-1231 x Finish

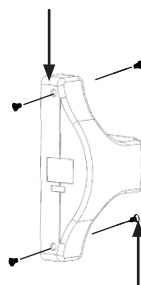

(4) 8-32 x 5/16" PFHMS  
81-0072-0406 x Finish

**Wide Cover**  
Optional for 2100(F)  
60-2000-1241 x Finish

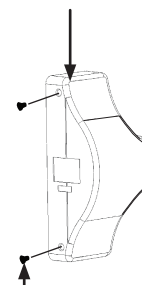

(2) 8-32 x 5/16" PFHMS  
81-0072-0406 x Finish

**Wide Cover**  
Optional for 1800(F)  
60-2000-1242-200

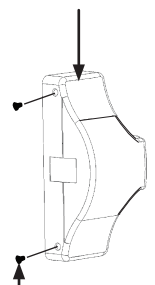

(2) 8-32 x 5/16" PFHMS  
81-0072-0406 x Finish

DEVICE	OPENING WIDTH	BAR ASSEMBLY	FINISH
2100, 2150, 1800 Dogging	36" (0.91m)	60-2100-0014	Specify
	42" (1.07m)	60-2100-0015	
	48" (1.22m)	60-2100-0088	
2100F, 2150F, 1800F (Non Dogging)	36" (0.91m)	60-2100-0008	
	42" (1.07m)	60-2100-0009	
	48" (1.22m)	60-2100-0087	

### For Doors of Either Hand Maintenance

1. Periodically remove covers and coat mechanisms with a silicone base lubricant. This is particularly required in corrosive environments for proper product function.
2. Check mounting fasteners periodically. Retighten if found loose. Apply screw locking compound (available at automotive part stores) or change part fasteners if screws continue to back up.
3. Periodic checks (and adjustments) of strikes are required to compensate for changes in the opening (e.g. door sagging).

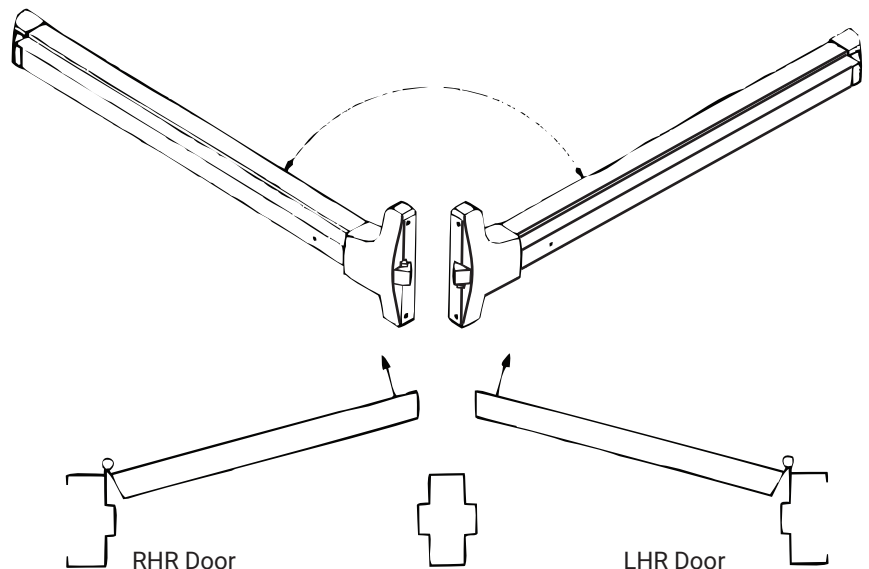

# 2100(F), 2150(F) & 1800(F)

## SquareBolt® and Rim Exit Devices Installation Instructions

# ACCENTRA

# ASSA ABLOY

### Check Before Starting Unreinforced Doors or Frames

Doors and Frames with walls having a structural thickness (metal skin plus reinforcement or solid hardwood) to engage less than (3) full screw threads are considered unreinforced.

Unreinforced Doors: Use SNB (sex nuts and bolts).

Unreinforced Frames: Use Blind Rivet Nuts.

Recommended fasteners for unreinforced openings are not necessarily supplied by ACCENTRA.

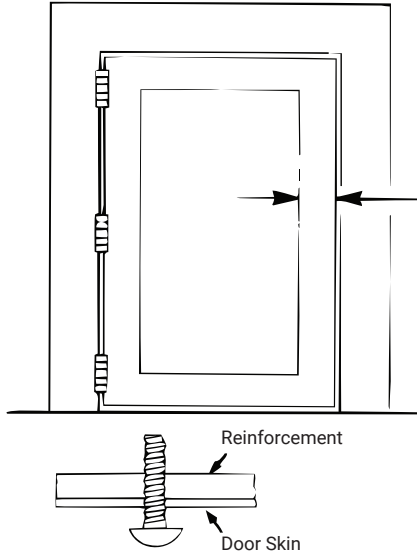

#### Min. Door Stile 4-1/2" (114mm)

Door and frame must meet structural and dimensional specifications on exit device template(s) for door and frame preparation.

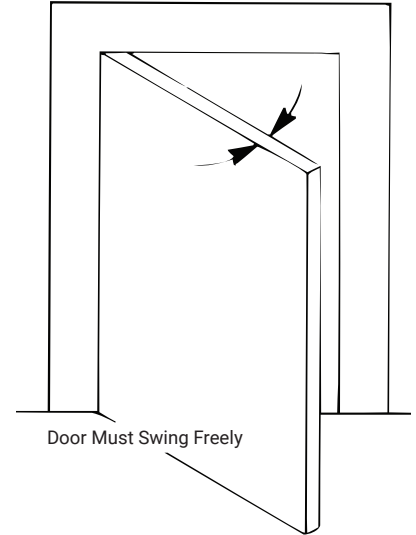

## 1. Mark Door

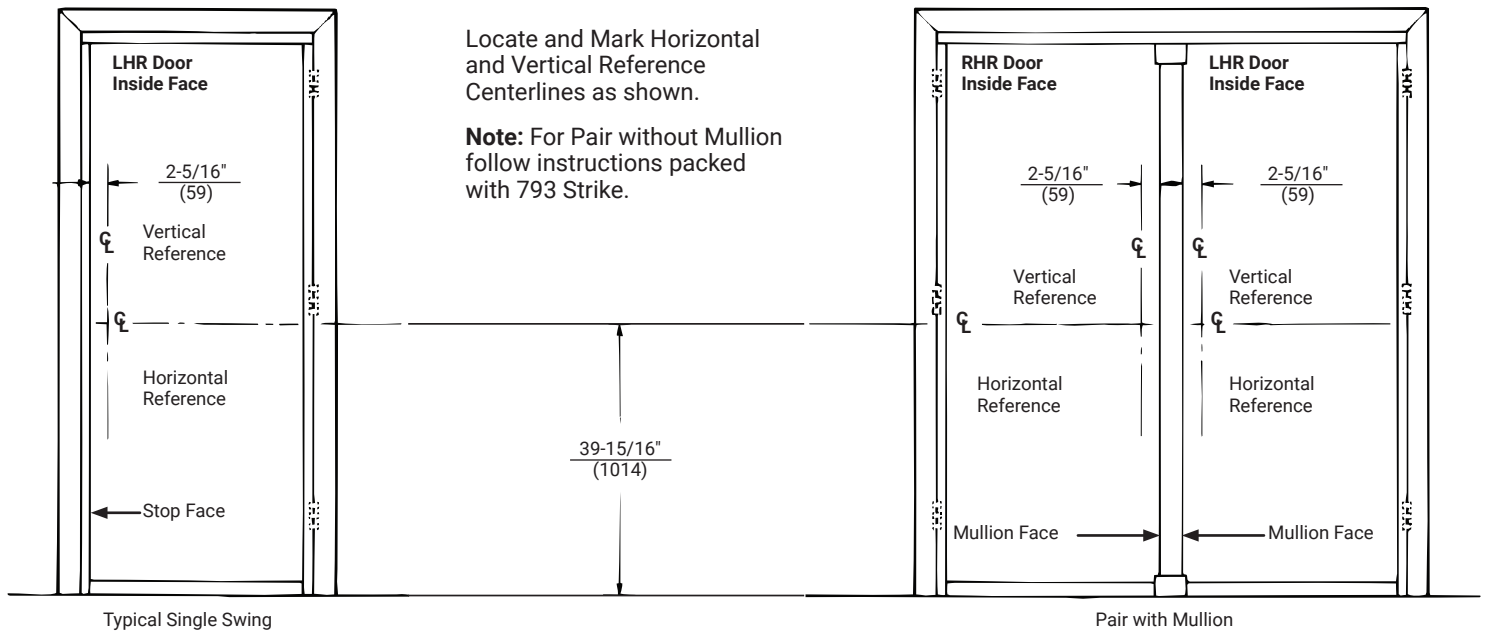

## 2. Prepare Door and Frame

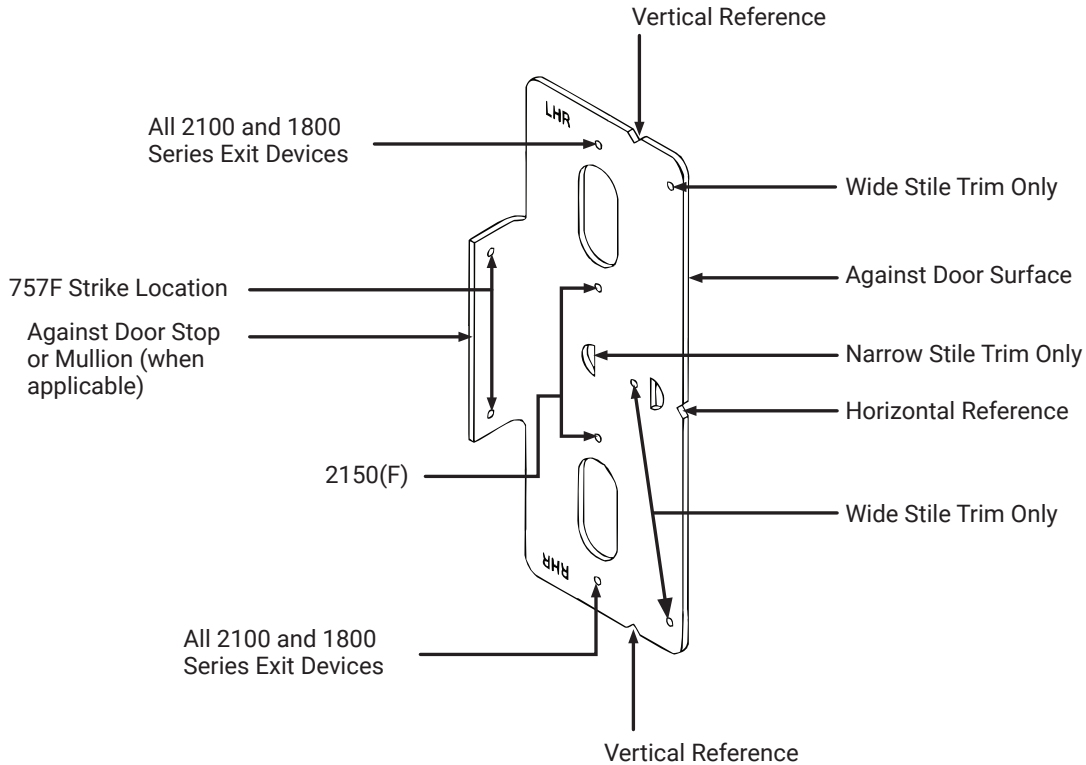

- Seat plastic template on door and stop faces.
  - Align horizontal and vertical centerlines.
  - Locate and tape Trim Template on door.  
(See instructions packed with Trim).
  - Spot and prepare holes.
- Device: Each (2) 1/4-20 Machine Screws\* OR (2) 3/8" (10) Dia. Optional Sex Nuts & Bolts. (\*) **Metal reinforced door only.**
- Strike: (2) 10-24 Machine Screws OR (2) #10 Wood Screws

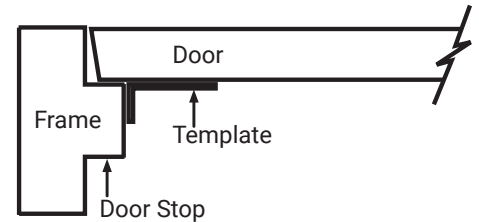

## 3. Clear Raised Molding

Device (head bar and end cap) must seat flush on door surface or on shims that keep it parallel to door face.

- Shim Kit #223 needed to clear each 1/8" (3mm) of raised molding. Longer mounting screws needed when more than two
- Shim Kits are used. See instructions provided with shim kits for installation.

# 2100(F), 2150(F) & 1800(F)

## SquareBolt® and Rim Exit Devices Installation Instructions

# ACCENTRA

# ASSA ABLOY

### 4. Mount Components

- A. Mount Trim (Follow instructions packed with trim).
- B. Mount Latch Case:
  - Use (2) 1/4-20 x 1" PRHMS or SNB for 2100(F), or 1800(F)
  - Use (4) 1/4-20 x 1" PRHMS or SNB for 2150(F)
- C. Open door. Slide Bar over door surface until touching Latch Case wall. Slider in Latch Case penetrates into Bar. (See Detail 1).
- D. Set Bar level.
- E. Size Bar. To cut Bar, see Detail 2.
- F. Reposition Bar (Detail 1). Clamp Bar with End Cap Bottom (Detail 3). Locate End Cap Bottom mounting holes.
- G. Prepare End Cap Bottom mounting holes. Mount End Cap Bottom (Detail 3). (2 ea. 1/4-20 PRHMS or 3/8" (10) dia. SNB).
- H. Check Bolt Retraction.

1. Depress bar (bolts must retract). Release bar (bolts must extend).
  2. Actuate trim (bolts must retract). Release trim actuator (bolts must extend).
  3. Depress touchbar, turn dogging key clockwise (bar must remain depressed, bolts must remain retracted). Turn dogging key counterclockwise (bar and bolts must return to extended position).
- I. Tighten all mounting screws.

**Note:** When resulting operation is faulty, check first for visible binding or interference. If there is no apparent reason for the fault, remove item from the door and recheck its operation before assuming that it is defective

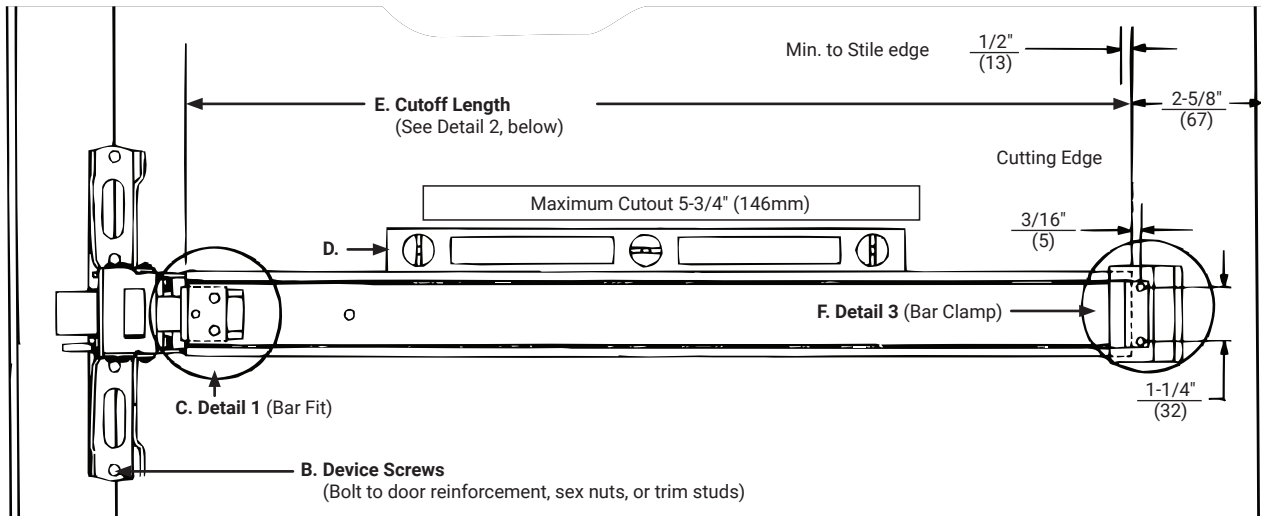

#### Detail 1: Fit Bar

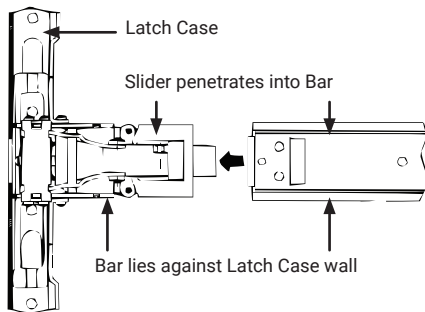

#### Detail 2: To Cut Bar

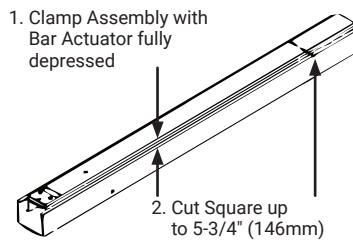

#### Detail 3: Clamp Bar

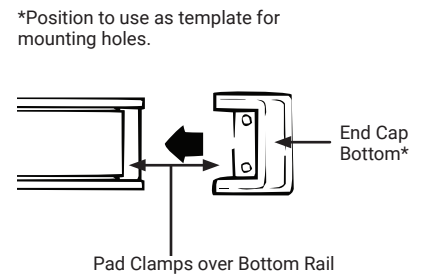

**5. Install Strike**

**Detail A**

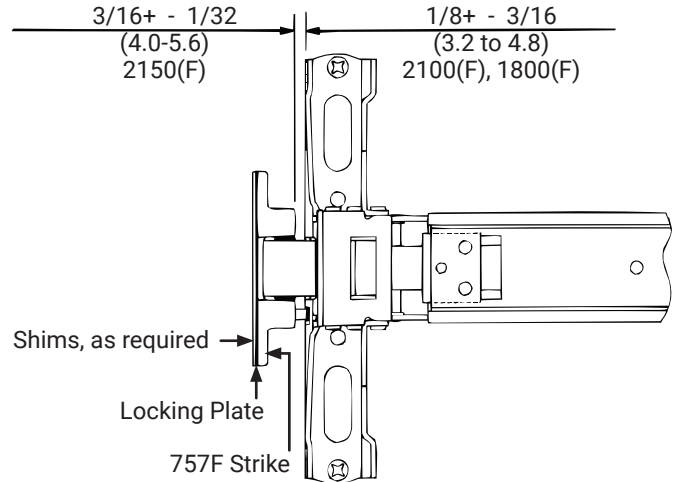

- A. Position Strike Projection  
 (Strike + Locking Plate + Shims, if needed).  
**See Detail A.**
- B. Position Strike Depth:
- 2100(F), 1800(F), **See Detail B.**
  - 2150(F), see **Detail B1**

**Detail B**

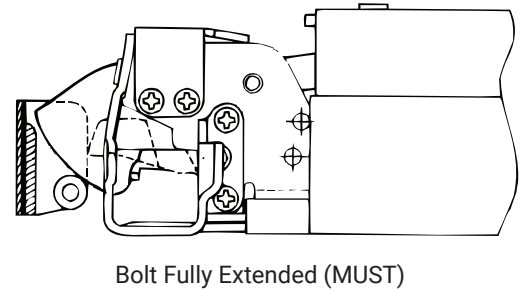

**Detail B1**

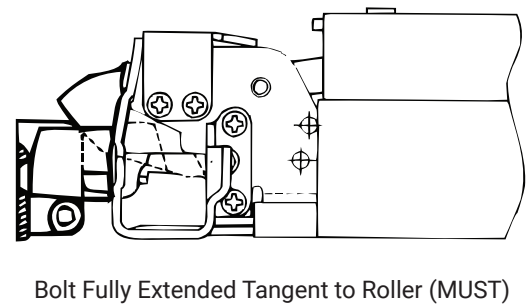

# 2100(F), 2150(F) & 1800(F)

## SquareBolt® and Rim Exit Devices Installation Instructions

ACCENTRA

ASSA ABLOY

- A. Fasten Strike Securely, as shown on **Detail C**.
- B. Check Bolt Engagement.
  - 1. Bolt should retract to clear the strike, when actuated by bar, trim, or dogging action. Bolt should consistently reengage the strike, when actuators are released and the door shuts.
  - 2. Door should remain latched and not rattle when pushed, pulled, or shaken in/out.
- C. (Required for Fire Devices only, optional for Panic) Lock strike in place. **See Detail E**.
  - 1. Prepare for and install strike center screw (1 #10-24 PFHMS). **See E1**.

- D. (Fire Mullion Installations Only) Stabilize strike. **See Detail F**.
  - 1. Position strike interlock bracket in place as shown. Locate bracket holes.
  - 2. Prepare interlock bracket mounting holes. Mount interlock bracket (4 #10-24 PFHMS or SNB).

**NOTES:** Interlock bracket and screws supplied with Fire Mullion.

**Detail C**

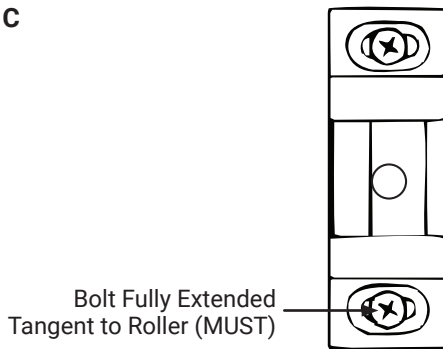

**Detail E**

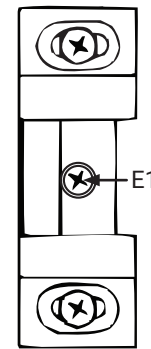

**Detail F**

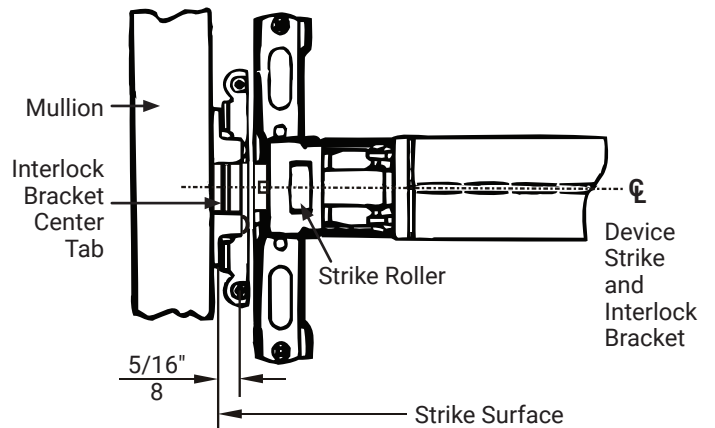
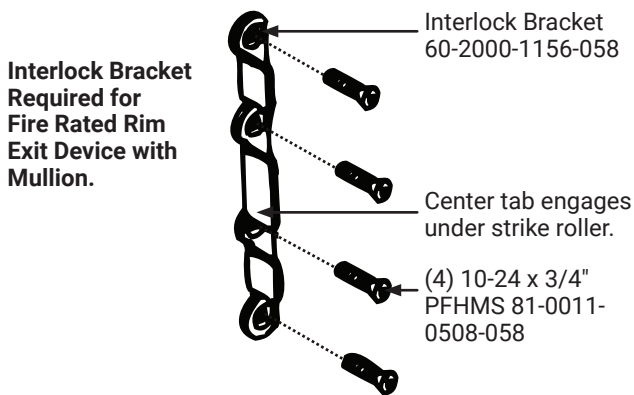

80-9421-0000-000 04/24

1-855-557-5078 Ext. 2 • [www.accentra-assaabloy.com](http://www.accentra-assaabloy.com)

Copyright © 2004, 2012, 2023, 2024, ASSA ABLOY ACCENTRA™ Access and Egress Hardware Group, Inc. All rights reserved. Reproduction in whole or in part without the express written permission of ASSA ABLOY Access and Egress Hardware Group, Inc. is prohibited.

Experience a safer  
and more open world

## 6. Install Head Cover & End Cap Top

Cover Detail

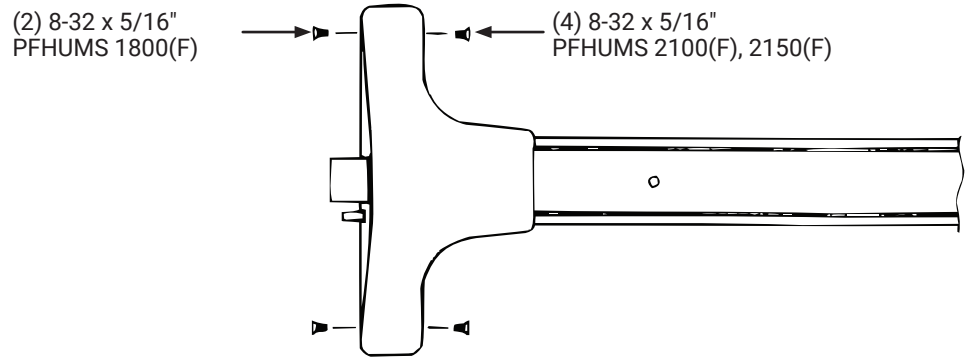

End Cap Detail

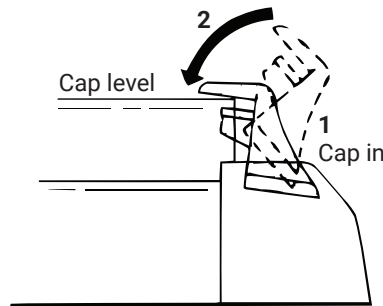

\*(1) 10-24 x 1/2" PPHFTCS

